

BigBox Washer CWR1001 ROTAR

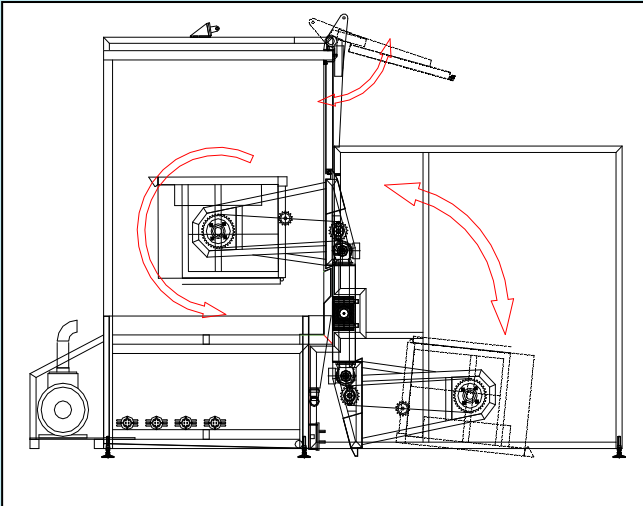

Technical specifications:

- Capacity: up to 25 Big Box/h
- Mainwash pump: 18 kW, 1500 l/min, 5 bar
- Pump: one step in stainless steel
- Mainwash tank: 1500 litre
- Watertemp. Mainwash: 45°C
- Watertemp. Afterrinse: up to 85°C
- Heating Mainwash: direct steaminjection or el
- PLC S7 Control
- ProFace Touchscreen
- Machine Size: 4100x2200x2850 mm

Options:

- Drum Filter
- Mechanical exhaust
- Detergent dispenser
- Blowing of containers
- Heating Afterrinse: steam heatexchanger or el

