

## Rackwasher RWD-30-1

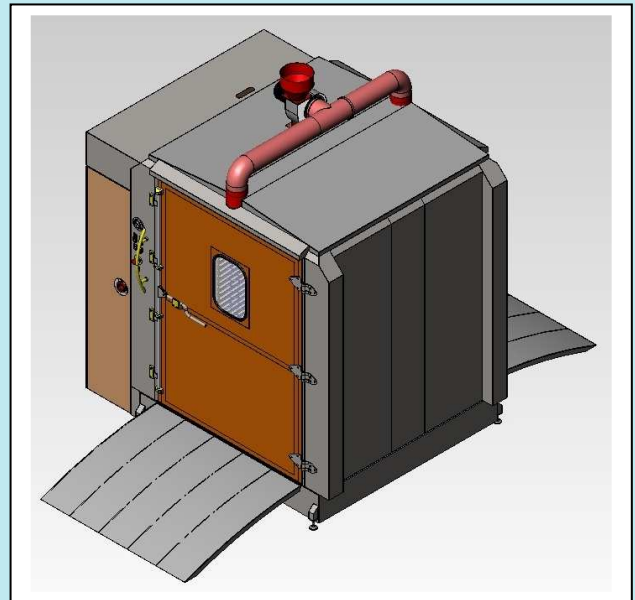
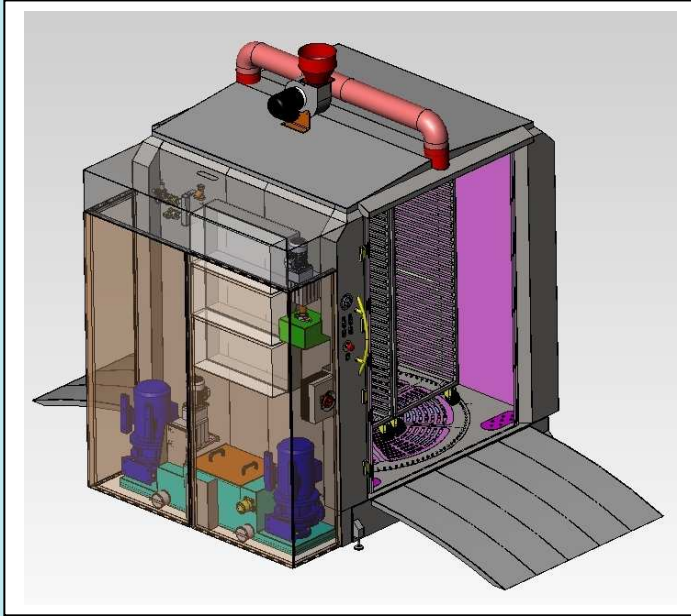

### Cleaning of Racks

#### Technical specifications:

- Capacity: 10 to 60 racks/hour
- 2 racks inside machine
- Pumps: 2 x 5,5 kW mainwash, each 500 l/min at 4 bar
- Effectiv washing with crossflow-spraying-system
- 2 door system: dirty inn – clean out
- Filterbasket
- 50°C hot mainwash
- 85°C hot afterrinse (option)
- Adjustable programming of washing
- Low waterconsumption
- Low noise, max. 85 dBA
- Exhaust ventilator (option)

